

MJ 2 SPDT HIGH RANGE PRESSURE SWITCHES

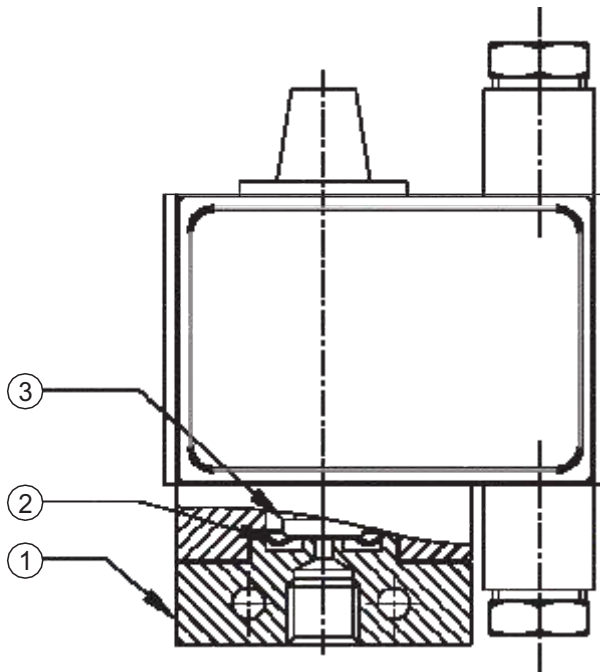

PRESSURE CAPSULE DETAILS



- No. Description**
1. Pressure housing
 2. Diaphragm
 3. Plunger

Note : *wetted parts* are mentioned in italics.

INSTALLATION DRAWING

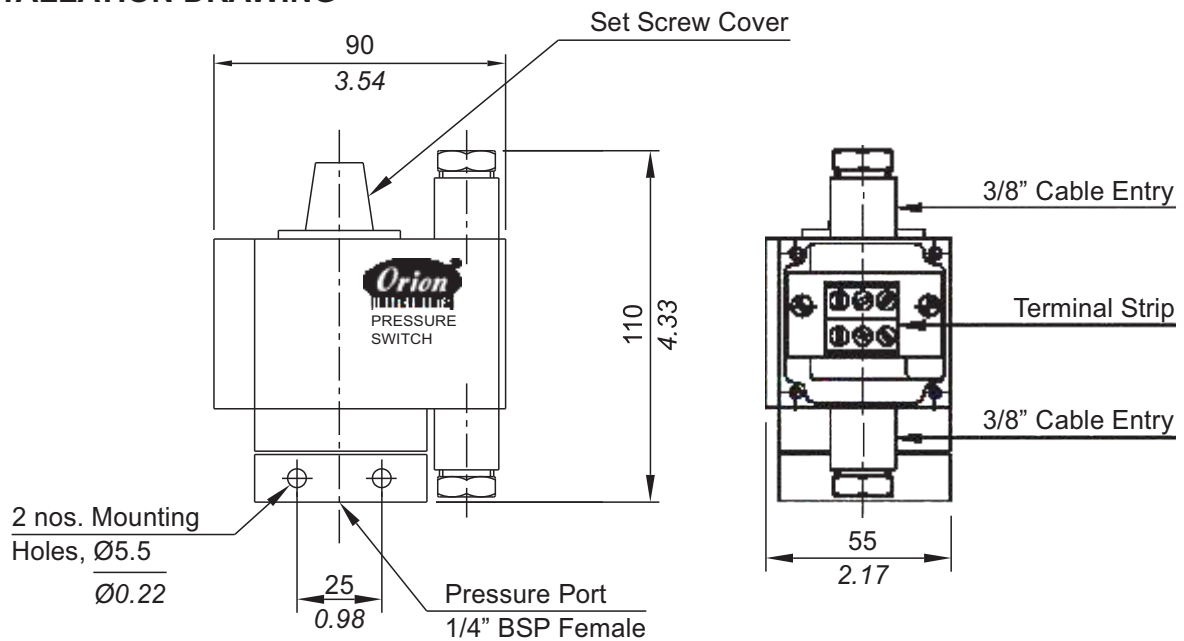

APPROX. DIMENSIONS IN $\frac{\text{mm}}{\text{inches}}$

2 SPDT HIGH RANGE PRESSURE SWITCHES

MJ

General information:

MJ series pressure switches are housed in pressure die cast aluminum powder coated enclosure and are recommended for panel mounting or outdoor service based on the type of enclosure opted for. No stage differential can be set in these 2SPDT versions (MJ series). Both micro switches are synchronized for operation within practical limits and a slight stage difference is bound to remain between the set points (generally not exceeding $\pm 2\%$ of FSR). The scale indicates the rising set point for one of the micro switches. The repeat accuracy is better than $\pm 2\%$ FSR. 3/8" cable entries are provided for cables and a terminal strip suitable for wired ends is fitted inside the enclosure. Other variations for cable termination, such as plugin connectors can be provided. Pressure port is 1/4" BSPF standard

Features:

- Compact
- Separate chamber for working parts
- Choice of wetted parts to suit working media
- Electrical rating : 5A, 250 VAC; 0.2 A, 250 VDC (res.)
- Proof pressure available can be 4 times MWP (optional)
- Pressure port : 1/4" BSPF

Some Applications :

Used in transformers, boilers, water treatment plants, firefighting systems, compressors, etc.

Range Selection Table

Range Code	Range (rising pressure) bar (psi)	Approximate Maximum Differential* (fixed) bar (psi)	Maximum Working Pressure bar (psi)
LP	† 0.067 - 0.213 (0.96 - 3.09)	0.04 (0.58)	5 (72.52)
H01	0.1 - 1.0 (1.45 - 14.50)	0.16 (2.32)	12 (174.05)
H02	0.1 - 1.5 (1.45 - 21.76)	0.20 (2.90)	12 (174.05)
H03	0.2 - 2.6 (2.90 - 37.71)	0.40 (5.80)	12 (174.05)
H04	0.2 - 3.6 (2.90 - 52.21)	0.40 (5.80)	12 (174.05)
H07	0.5 - 7.0 (7.25 - 101.52)	0.80 (11.60)	12 (174.05)
H10	0.5 - 10.0 (7.25 - 145.04)	1.20 (17.40)	25 (362.6)
H15	1.0 - 15.0 (14.50 - 217.71)	1.20 (17.40)	25 (362.6)
H30	5.0 - 25.0 (72.52 - 362.6)	3.00 (43.51)	35 (507.63)

*Minimum differential increases with setpoint (Graphs available on request)

† approx 50 mmHg to 160 mmHg. Scale Calibrated in mmHg for this range only.

How to order MJ series 2SPDT high range pressure switches

Group 1	Group 2	Group 3	Group 4	Group 5	Group 6
Model	Range Code	Range Scale	Pressure Housing	Diaphragm	Enclosure
MJ - 2 SPDT Fixed differential Switch	H - High Pressure range	U - without scale C - with a scale corresponding to low microswitch	A Aluminium B -Brass S -SS 316	0 - Neoprene 1 - Teflon	0 - Standard (IP 54) 1 - IP65 as per IS 2147
			for special wetted parts through chemical seals, please refer page 330,331 & 332 and specify in text accordingly.		

eg. A 2SPDT fixed differential switch, high pressure range from 0.1-1.0 bar in calibrated style with brass pressure housing, a teflon diaphragm & a standard enclosure shall be specified by

Group 1	Group 2	Group 3	Group 4	Group 5	Group 6
MJ	H01	C	B	1	0

Please specify full model number to avoid ambiguity. If only the first two groups are specified while ordering, uncalibrated switches with standard wetted parts and a standard enclosure will be supplied

Continuous efforts for product development may necessitate changes in these details without notice

Authorised Dealer



NK Instruments Pvt. Ltd.

B-501/504, 5th floor, Raunak Arcade, Near THC Hospital, Gokhale Road, Naupada,
Thane(W) 400602. Maharashtra INDIA
E-Mail: sales@nkinstruments.com
Skype: nitinkelkarskype

Telefax Nos.: 91-22-25301330 / 31 / 32
Web: <http://www.nkinstruments.com>
Gtalk: nkinstruments2006

