

**PRESSURE SWITCHES
PRESSURE DIFFERENCE SWITCHES
VACUUM SWITCHES**
From 1.5 mbar to 600 bar

MT Hydraulic Diaphragm Switches

CATALOGUE



Authorised Dealer



NK Instruments Pvt. Ltd.

B-501/504, 5th floor, Raunak Arcade, Near THC Hospital, Gokhale Road, Naupada,
Thane(W) 400602. Maharashtra INDIA Telefax Nos.: 91-22-25301330 / 31 / 32
E-Mail: sales@nkstruments.com Web: <http://www.nkstruments.com>
Skype: nitinkelkarskype Gtalk: nkstruments2006



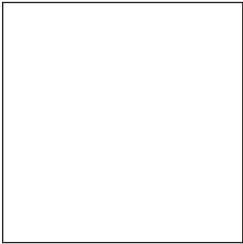

PRESSURE CAPSULE DETAILS

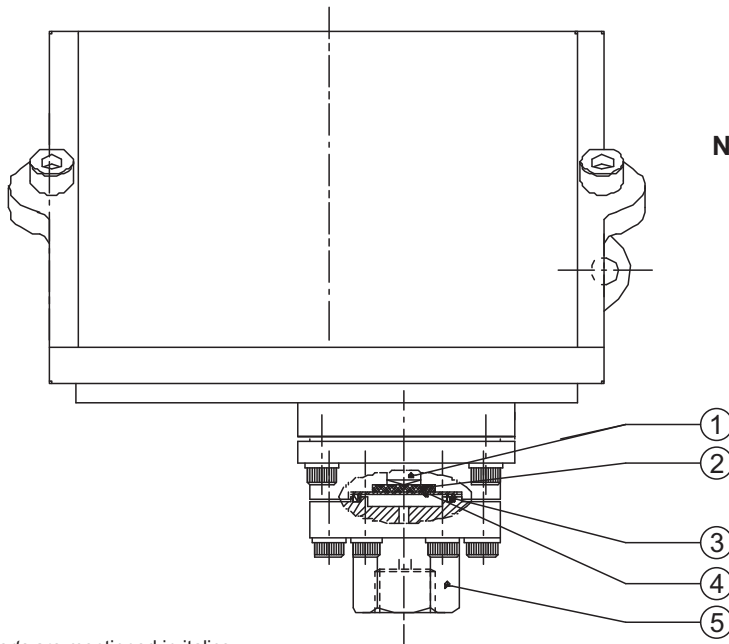

No. Description

1. Transfer Pin
2. Cushioning Pad
3. Teflon 'O' ring
4. Diaphragm
5. Pressure Housing

Note : *wetted parts* are mentioned in italics.

*Pressure ports are brazed with flange

INSTALLATION DRAWING

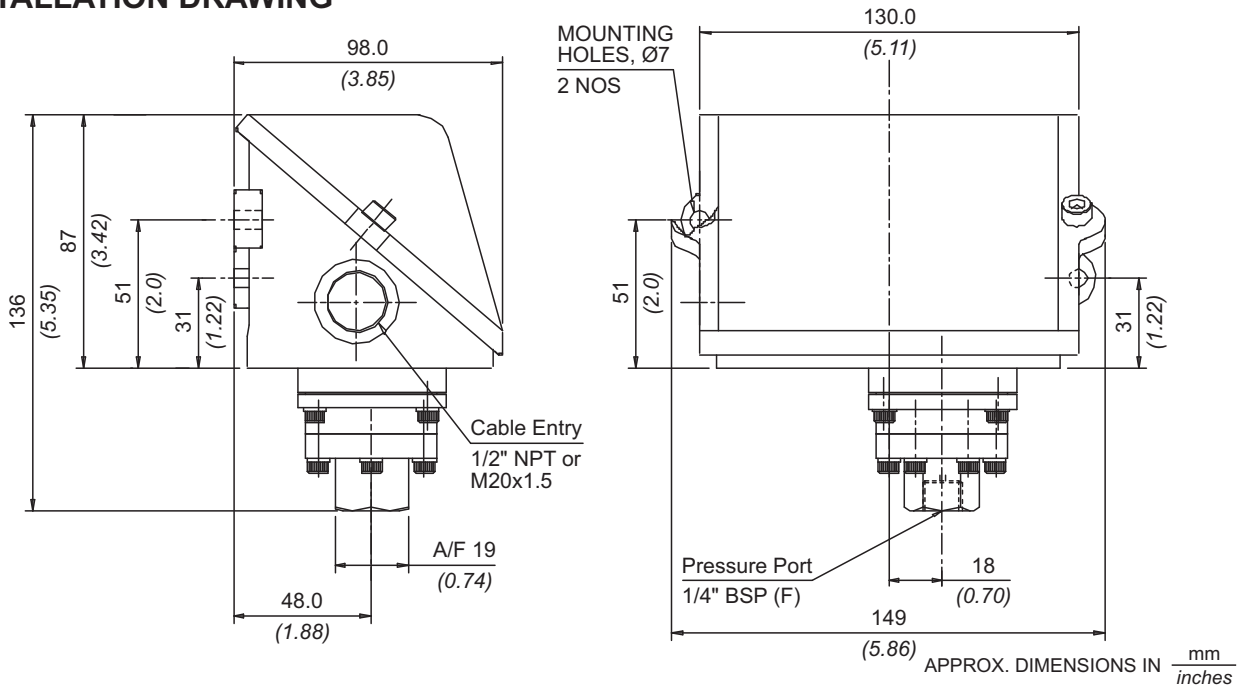

APPROX. DIMENSIONS IN $\frac{\text{mm}}{\text{inches}}$

HYDRAULIC DIAPHRAGM SWITCH **MT**

RANGE SELECTION TABLE

Range Code	Range bar (<i>psi</i>)	Differential* bar (<i>psi</i>)	Maximum Working Pressure bar (<i>psi</i>)
		Approximate Maximum for "A1" microswitch	
H1T	0.5 - 10 (7.25 - 145.04)	0.5 (7.25)	150 (2175.57)
H2T	2 - 20 (29.00 - 290.07)	2 (29.00)	200 (2900.76)
H4T	5 - 40 (72.52 - 580.15)	5 (72.52)	200 (2900.76)
H1H	10 - 100 (145.04 - 1450.38)	12 (174.05)	200 (2900.76)
H2H	7 - 200 (101.53 - 2900.76)	24 (348.09)	400 (5801.52)
H4H	40 - 400 (580.15 - 5801.52)	70 (1015.27)	500 (7251.9)

*Minimum differential increases with setpoint, values with neoprene diaphragm (Graphs available on request)

* Differentials of microswitches A2 through A9 will vary. Differentials for A7 are typically twice that for A1 microswitch. Please indicate specifically the differential value in enquiry/order, when it is critical in your application.

HOW TO ORDER INDUSTRIAL HYDRAULIC DIAPHRAGM RANGE PRESSURE SWITCHES

Group 1	Group 2	Group 3	Group 4	Group 5	Group 6	Group 7	Group 8
Non standard allocation <input type="checkbox"/> Reserved for non-standard options not covered in catalogue. Will be given by manufacturer, only after agreement of supply details with customer.	Gas Group Classification MT = Industrial pressure switch with diecast Aluminium enclosure to IP66 as per IS/IEC 60529	Cable Entry Size 1 = Al. head 1/2" NPT threads 3 = Al. head M20 X 1.5 threads	Switch Type PF1 = pressure switch, fixed differential without scale PF2 = pressure switch, fixed differential with scale in bar PF3 = pressure switch, fixed differential with scale in psi *PA1 = pressure switch, adjustable differential without scale *PA2 = pressure switch, adjustable differential with scale in bar *PA3 = pressure switch, adjustable differential with scale in psi *Available with A9 (in group 6) only	Range Code (values in bar) H1T = (0.5 - 10) H2T = (2 - 20) H4T = (5 - 40) H1H = (10 - 100) H2H = (7 - 200) H4H = (40 - 400)	Microswitch Type A1 = General purpose microswitch rated at 15 A; 250 VAC *A2 = Hermetically sealed for corrosive environments *A3 = gold plated contacts for low voltage applications *A4 = DPDT configuration *A5 = for high DC ratings *A7 = 2SPDT switching elements *A9 = General purpose microswitch rated at 5 A; 250 VAC	Pressure Port Material / Size S1 = SS316 / 1/4" BSP(F) S2 = SS316 / 1/4" NPT(F)	Diaphragm 2 = SS316L

eg. A hydraulic diaphragm pressure switch, with 1/2" NPT cable entry in aluminium housing as 1SPDT pressure switch, fixed differential without scale, having 5 bar to 40 bar pressure range, with 15Amp. microswitch, SS316 pressure housing with 1/4" BSP port size shall be specified by

Group 1	Group 2	Group 3	Group 4	Group 5	Group 6	Group 7	Group 8
□	MT	1	PF1	H4T	A1	S1	2

Please specify full model number to avoid ambiguity. If only the first two groups are specified while ordering, uncalibrated switches with standard wetted parts and enclosures will be supplied.